

Sonnenschein A500

Технические особенности:

- Номинальная емкость 1,20 – 200 А·ч C_{20}
- Высокие емкостные характеристики и длительный срок службы
- Решетчатая пластина с высококачественным сплавом свинца и кальция для улучшенной удельной энергоемкости
- Минимальное газовыделение благодаря внутренней рекомбинации газов
- Высокая устойчивость к многократным циклам заряда и разряда
- Срок хранения: до 2 лет без подзаряда при 20 °С благодаря низкой скорости саморазряда

Стандарты и сертификаты:

- Классификация по EUROBAT 2015: 10 – 12 лет – Very long life
- Создано в соответствии со стандартом IEC 60896-21/22
- Нет ограничений для большинства видов железнодорожных, автомобильных, морских и воздушных перевозок (IATA, DGR, пункт A67)
- Произведено в Европе на наших сертифицированных предприятиях ISO 9001
- Одобрено: UL (Underwriters Laboratories, США), VdS, DNV GL (Germanischer Lloyd), DIN-GOST TÜV (Россия)



Длительный срок службы 10 – 12 лет



Номинальная емкость 1,20 – 200 А·ч C_{20}



Моноблочное исполнение



Решетчатая пластина



Подлежит переработке

VRLA

Свинцово-кислотные аккумуляторы с регулируемым клапаном



Защита от глубокого разряда



Не требует обслуживания (долива воды)

Корпус, выводы и момент затяжки

1,2 – 16 А·ч = ABS

25 – 200 А·ч = Полипропилен (PP)

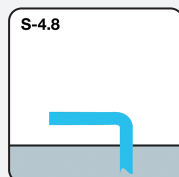

S-4.8



G-M5

5 Нм



G-M6

6 Нм

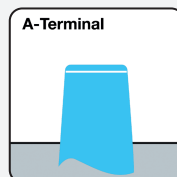

A-Terminal

8 Нм



Эксклюзивный дистрибьютор продукции Exide Technologies на территории Республики Казахстан
accu-energo.kz



Sonnenschein A500

Технические характеристики

Тип	Артикул	Ном. напр. В	Ном. емкость	Длина	Ширина	Высота	Высота	Масса**	Внутр. сопр. МОм	Ток кор. замык. А***	Тип выводов
			С ₁₀ 1,75 В/эл. 20 °С	(l)	(w)	(h1)	(h2)				
			А-ч	макс. мм	макс. мм	макс. мм	макс. мм				
A502/10 S	NGA5020010HS0SA	2	10,0	52,9	50,5	94,5	98,4	0,70	11,2	189	S-4,8
A504/3,5 S	NGA50403D5HS0SA	4	3,50	90,5	34,5	60,5	64,4	0,50	48,0	88,0	S-4,8
A506/1,2 S	NGA50601D2HS0SA	6	1,20	97,3	25,5	51,0	55,6	0,33	165	38,0	S-4,8
A506/3,5 S	NGA50603D5HS0SA	6	3,50	135	34,8	60,5	64,4	0,70	71,0	88,0	S-4,8
A506/6,5 S	NGA50606D5HS0SA	6	6,50	152	34,5	94,5	98,4	1,30	48,0	131	S-4,8
A506/10 S*	NGA5060010HS0SA	6	10,0	152	50,5	94,5	98,4	2,10	34,0	189	S-4,8
A508/3,5 S	NGA50803D5HS0SA	8	3,50	179	34,1	60,5	64,4	1,00	95,0	88,0	S-4,8
A512/1,2 S*	NGA51201D2HS0SA	12	1,20	97,5	49,5	51,0	54,9	0,65	330	38,0	S-4,8
A512/2 S*	NGA5120002HS0SA	12	2,00	179	34,1	60,5	64,4	1,00	172	73,0	S-4,8
A512/3,5 S*	NGA51203D5HS0SA	12	3,50	135	66,8	60,5	64,4	1,50	142	88,0	S-4,8
A512/6,5 S*	NGA51206D5HS0SA	12	6,50	152	65,5	94,5	98,4	2,60	95,0	131	S-4,8
A512/10 S*	NGA5120010HS0SA	12	10,0	152	98,0	94,5	98,4	4,00	66,0	189	S-4,8
A512/16 G5*	NGA5120016HS0BA	12	16,0	181	76,0	167	167	6,00	37,8	340	G-M5
A512/25 G5*	NGA5120025HS0BA	12	25,0	167	176	126	126	9,60	28,0	463	G-M5
A512/30 G6*	NGA5120030HS0BA	12	30,0	197	132	161	180	11,1	21,8	586	G-M6
A512/40 A*	NGA5120040HS0CA	12	40,0	210	175	175	175	14,2	16,5	770	A-Terminal
A512/40 G6*	NGA5120040HS0BA	12	40,0	210	175	175	175	14,2	16,5	770	G-M6
A512/55 A	NGA5120055HS0CA	12	55,0	261	135	208	230	18,1	10,9	1147	A-Terminal
A512/60 A	NGA5120060HS0CA	12	60,0	278	175	190	190	20,3	14,0	936	A-Terminal
A512/60 G6	NGA5120060HS0BA	12	60,0	278	175	190	190	20,3	14,0	936	G-M6
A512/65 A	NGA5120065HS0CA	12	65,0	353	175	190	190	23,0	8,30	1471	A-Terminal
A512/65 G6	NGA5120065HS0BA	12	65,0	353	175	190	190	23,0	8,30	1471	G-M6
A512/85 A*	NGA5120085HS0CA	12	85,0	330	171	213	236	29,2	7,40	1693	A-Terminal
A512/115 A	NGA5120115HS0CA	12	115	286	269	208	230	37,5	5,50	2275	A-Terminal
A512/120 A	NGA5120120HS0CA	12	120	513	189	195	219	39,0	5,10	2475	A-Terminal
A512/140 A	NGA5120140HS0CA	12	140	513	223	195	219	47,0	4,10	3132	A-Terminal
A512/200 A	NGA5120200HS0CA	12	200	518	274	216	238	63,5	3,80	3370	A-Terminal

* Сертификат VDS

** Фактическая масса может отличаться на ±5%

*** Макс. нагрузка с подходящими контактами

Sonnenschein A500

Чертежи

A502/10 S

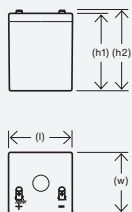

A504/3.5 S

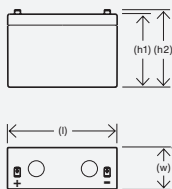

A506/1.2 S

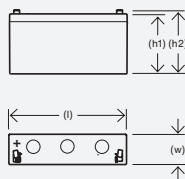

A506/3.5 S

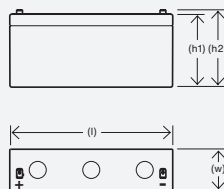

A506/6.5 S

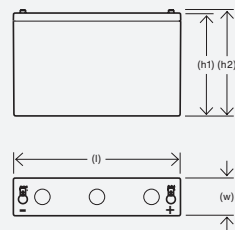

A506/10 S

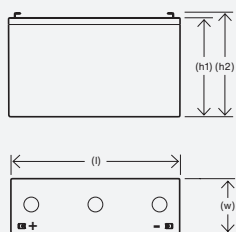

A508/3.5 S



A512/1.2 S

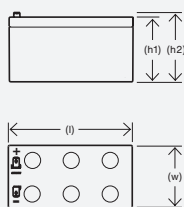

A512/2 S

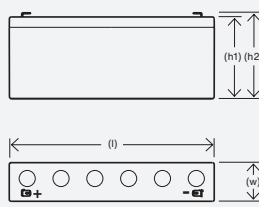

A512/3.5 S

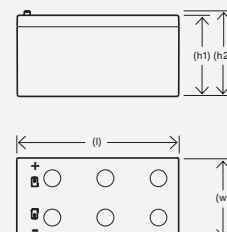

A512/6.5 S

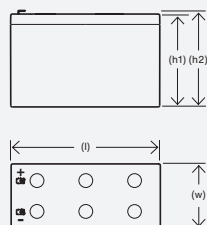

A512/10 S

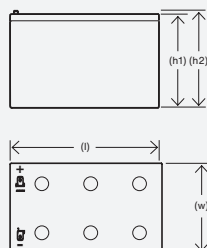

A512/16 G5

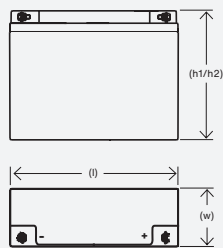

A512/25 G5

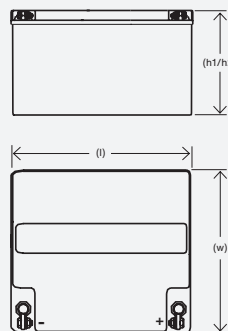

A512/30 G6

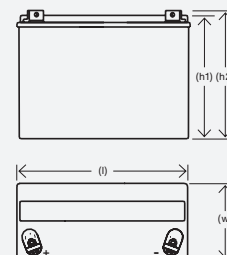

Не в масштабе!

Sonnenschein A500

Чертежи

A512/40 A
(A512/40 G6)*

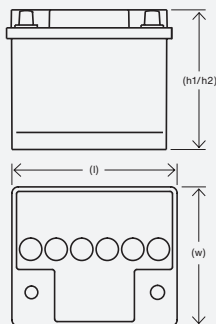

A512/55 A

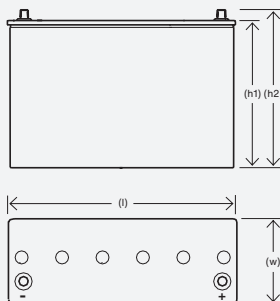

A512/60 A
(A512/60 G6)*

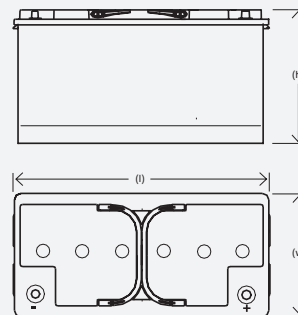

A512/65 A
(A512/65 G6)*

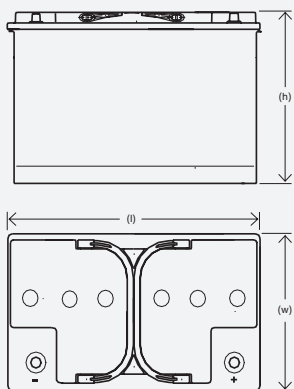

A512/85 A

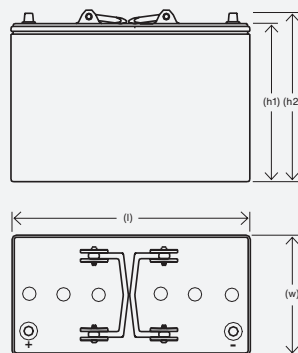

A512/115 A

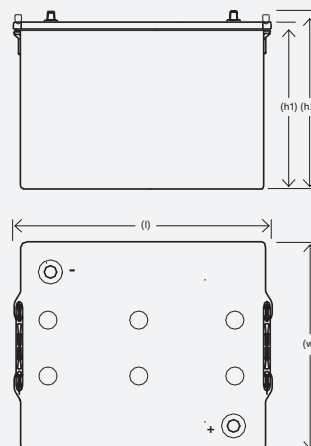

A512/120 A

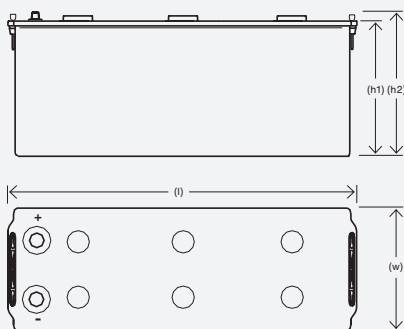

A512/140 A

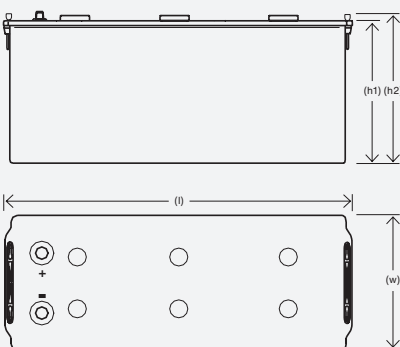

A512/200 A

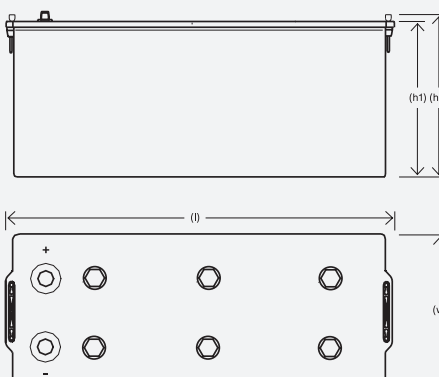

Не в масштабе!

* Размеры подходят для исполнений с другими выводами

Sonnenschein A500

Разряд постоянным током

Тип	Артикул	5 мин.	10 мин.	15 мин.	20 мин.	30 мин.	1 ч.	2 ч.	3 ч.	5 ч.	8 ч.	10 ч.
-----	---------	--------	---------	---------	---------	---------	------	------	------	------	------	-------

1,85 В/эл – разряд постоянным током в А при 20 °С

A502/10 S	NGA5020010HSOSA	30,0	22,0	18,0	15,0	11,2	6,40	3,90	2,80	1,80	1,18	0,96
A504/3,5 S	NGA50403D5HSOSA	9,50	6,70	5,50	4,50	3,40	2,10	1,40	0,95	0,60	0,39	0,32
A506/1,2 S	NGA50601D2HSOSA	3,52	2,44	1,92	1,58	1,20	0,75	0,49	0,34	0,21	0,13	0,10
A506/3,5 S	NGA50603D5HSOSA	9,50	6,70	5,50	4,50	3,40	2,10	1,40	0,95	0,60	0,39	0,32
A506/6,5 S	NGA50606D5HSOSA	17,0	12,0	10,0	8,10	6,10	3,60	2,10	1,50	1,10	0,73	0,61
A506/10 S	NGA5060010HSOSA	30,0	22,0	18,0	15,0	11,2	6,40	3,90	2,80	1,80	1,18	0,96
A508/3,5 S	NGA50803D5HSOSA	9,50	6,70	5,50	4,50	3,40	2,10	1,40	0,95	0,60	0,39	0,32
A512/1,2 S	NGA51201D2HSOSA	3,52	2,44	1,92	1,58	1,20	0,75	0,49	0,34	0,21	0,13	0,10
A512/2 S	NGA5120002HSOSA	5,40	3,70	3,20	2,60	2,00	1,50	0,82	0,56	0,34	0,22	0,18
A512/3,5 S	NGA51203D5HSOSA	9,50	6,70	5,50	4,50	3,40	2,10	1,40	0,95	0,60	0,39	0,32
A512/6,5 S	NGA51206D5HSOSA	17,0	12,0	10,0	8,10	6,10	3,60	2,10	1,50	1,10	0,73	0,61
A512/10 S	NGA5120010HSOSA	30,0	22,0	18,0	15,0	11,2	6,40	3,90	2,80	1,80	1,18	0,96
A512/16 G5	NGA5120016HSOBA	40,0	29,0	24,0	20,0	15,0	9,80	6,21	4,34	2,70	1,80	1,40
A512/25 G5	NGA5120025HSOBA	41,1	36,2	29,0	24,8	20,5	13,1	8,00	5,80	3,90	2,50	2,10
A512/30 G6	NGA5120030HSOBA	60,7	49,3	44,0	36,5	28,0	18,0	10,6	7,60	4,90	3,20	2,60
A512/40 A	NGA5120040HSOCA*	75,0	63,0	50,0	42,0	34,0	22,0	12,0	8,80	6,40	4,30	3,50
A512/55 A	NGA5120055HSOCA	99,2	83,1	70,1	59,1	46,4	32,7	18,9	13,6	9,00	6,00	4,90
A512/60 A	NGA5120060HSOCA*	122	100	82,4	69,2	54,2	33,8	21,5	15,3	9,90	6,60	5,40
A512/65 A	NGA5120065HSOCA*	95,8	83,1	73,9	65,8	56,4	35,8	23,0	16,6	11,0	7,40	6,10
A512/85 A	NGA5120085HSOCA	168	141	119	100	78,0	53,0	30,0	22,0	14,2	9,40	7,70
A512/115 A	NGA5120115HSOCA	210	179	152	128	100	60,0	36,0	26,0	18,0	12,0	10,1
A512/120 A	NGA5120120HSOCA	257	201	162	135	104	65,5	39,3	27,8	18,1	11,9	9,80
A512/140 A	NGA5120140HSOCA	275	220	178	151	118	75,1	45,7	32,5	21,3	14,0	11,5
A512/200 A	NGA5120200HSOCA	329	274	226	196	160	104	65,1	46,6	31,0	20,4	16,7

1,80 В/эл – разряд разряд постоянным током в А при 20 °С

A502/10 S	NGA5020010HSOSA	33,0	24,0	19,0	16,0	11,9	6,80	4,10	2,90	1,90	1,23	1,00
A504/3,5 S	NGA50403D5HSOSA	10,6	7,40	6,00	4,90	3,70	2,20	1,40	0,98	0,62	0,40	0,33
A506/1,2 S	NGA50601D2HSOSA	3,92	2,67	2,07	1,69	1,26	0,77	0,51	0,35	0,21	0,13	0,10
A506/3,5 S	NGA50603D5HSOSA	10,6	7,40	6,00	4,90	3,70	2,20	1,40	0,98	0,62	0,40	0,33
A506/6,5 S	NGA50606D5HSOSA	19,0	13,0	11,0	8,80	6,50	3,80	2,20	1,60	1,10	0,75	0,63
A506/10 S	NGA5060010HSOSA	33,0	24,0	19,0	16,0	11,9	6,80	4,10	2,90	1,90	1,23	1,00
A508/3,5 S	NGA50803D5HSOSA	10,6	7,40	6,00	4,90	3,70	2,20	1,40	0,98	0,62	0,40	0,33
A512/1,2 S	NGA51201D2HSOSA	3,92	2,67	2,07	1,69	1,26	0,77	0,51	0,35	0,21	0,13	0,10
A512/2 S	NGA5120002HSOSA	6,20	4,20	3,40	2,80	2,10	1,50	0,86	0,58	0,36	0,23	0,19
A512/3,5 S	NGA51203D5HSOSA	10,6	7,40	6,00	4,90	3,70	2,20	1,40	0,98	0,62	0,40	0,33
A512/6,5 S	NGA51206D5HSOSA	19,0	13,0	11,0	8,80	6,50	3,80	2,20	1,60	1,10	0,75	0,63
A512/10 S	NGA5120010HSOSA	33,0	24,0	19,0	16,0	11,9	6,80	4,10	2,90	1,90	1,23	1,00
A512/16 G5	NGA5120016HSOBA	47,0	33,0	27,0	22,0	16,0	10,2	6,43	4,40	2,80	1,80	1,50
A512/25 G5	NGA5120025HSOBA	46,1	38,8	32,1	27,0	21,3	13,8	8,30	6,00	4,00	2,60	2,20
A512/30 G6	NGA5120030HSOBA	75,5	54,8	47,2	39,9	30,0	19,1	11,2	7,90	5,10	3,30	2,70
A512/40 A	NGA5120040HSOCA*	86,0	69,0	57,0	47,0	36,0	23,0	13,0	9,20	6,70	4,40	3,60
A512/55 A	NGA5120055HSOCA	114	89,8	78,7	65,3	50,2	34,2	19,5	14,0	9,20	6,10	5,00
A512/60 A	NGA5120060HSOCA*	145	108	91,9	75,9	58,1	35,5	22,3	15,8	10,3	6,80	5,60
A512/65 A	NGA5120065HSOCA*	120	100	88,1	75,4	60,4	38,6	24,3	17,4	11,5	7,50	6,20
A512/85 A	NGA5120085HSOCA	193	154	135	112	85,0	56,0	32,0	23,0	14,7	9,80	8,00
A512/115 A	NGA5120115HSOCA	244	192	170	140	107	64,0	38,0	27,0	18,0	13,0	10,4
A512/120 A	NGA5120120HSOCA	293	221	178	147	112	69,5	40,9	28,9	18,6	12,3	10,2
A512/140 A	NGA5120140HSOCA	315	244	198	166	128	79,7	47,7	33,8	22,0	14,5	11,9
A512/200 A	NGA5120200HSOCA	381	313	258	222	176	110	68,1	48,5	32,0	21,1	17,3

* Характеристики разряда действительны для других выводов / корпусов

Sonnenschein A500

Разряд постоянным током

Тип	Артикул	5 мин.	10 мин.	15 мин.	20 мин.	30 мин.	1 ч.	2 ч.	3 ч.	5 ч.	8 ч.	10 ч.
-----	---------	--------	---------	---------	---------	---------	------	------	------	------	------	-------

1,75 В/эл – разряд постоянным током в А при 20 °С

A502/10 S	NGA5020010HSOSA	35,0	26,0	20,0	17,0	12,3	6,90	4,20	3,00	1,90	1,25	1,02
A504/3,5 S	NGA50403D5HSOSA	11,3	7,90	6,20	5,10	3,80	2,30	1,40	0,99	0,62	0,41	0,34
A506/1,2 S	NGA50601D2HSOSA	4,12	2,82	2,15	1,74	1,30	0,78	0,51	0,35	0,22	0,13	0,10
A506/3,5 S	NGA50603D5HSOSA	11,3	7,90	6,20	5,10	3,80	2,30	1,40	0,99	0,62	0,41	0,34
A506/6,5 S	NGA50606D5HSOSA	20,0	14,0	11,0	9,20	6,80	3,90	2,30	1,60	1,10	0,76	0,63
A506/10 S	NGA5060010HSOSA	35,0	26,0	20,0	17,0	12,3	6,90	4,20	3,00	1,90	1,25	1,02
A508/3,5 S	NGA50803D5HSOSA	11,3	7,90	6,20	5,10	3,80	2,30	1,40	0,99	0,62	0,41	0,34
A512/1,2 S	NGA51201D2HSOSA	4,12	2,82	2,15	1,74	1,30	0,78	0,51	0,35	0,22	0,13	0,10
A512/2 S	NGA5120002HSOSA	6,80	4,60	3,50	2,90	2,20	1,50	0,87	0,59	0,36	0,24	0,19
A512/3,5 S	NGA51203D5HSOSA	11,3	7,90	6,20	5,10	3,80	2,30	1,40	0,99	0,62	0,41	0,34
A512/6,5 S	NGA51206D5HSOSA	20,0	14,0	11,0	9,20	6,80	3,90	2,30	1,60	1,10	0,76	0,63
A512/10 S	NGA5120010HSOSA	35,0	26,0	20,0	17,0	12,3	6,90	4,20	3,00	1,90	1,25	1,02
A512/16 G5	NGA5120016HSOBA	51,0	36,0	28,0	23,0	17,0	10,4	6,53	4,50	2,90	1,80	1,54
A512/25 G5	NGA5120025HSOBA	54,2	41,4	34,5	28,6	21,9	14,2	8,50	6,10	4,00	2,70	2,20
A512/30 G6	NGA5120030HSOBA	84,7	60,3	49,0	42,0	31,3	19,7	11,5	8,10	5,20	3,40	2,80
A512/40 A	NGA5120040HSOCA*	103	74,0	61,0	50,0	37,0	24,0	13,0	9,40	6,80	4,50	3,70
A512/55 A	NGA5120055HSOCA	139	99,0	84,3	69,5	52,5	35,0	19,9	14,2	9,30	6,20	5,10
A512/60 A	NGA5120060HSOCA*	168	118	98,3	80,4	60,5	36,4	22,7	16,1	10,4	6,90	5,60
A512/65 A	NGA5120065HSOCA*	140	111	95,7	81,9	63,8	40,0	24,9	17,8	11,7	7,60	6,30
A512/85 A	NGA5120085HSOCA	226	169	144	120	90,0	58,0	33,0	23,0	15,0	9,90	8,10
A512/115 A	NGA5120115HSOCA	282	204	179	148	112	66,0	39,0	28,0	19,0	13,0	10,5
A512/120 A	NGA5120120HSOCA	330	235	188	155	116	71,6	41,9	29,5	19,0	12,6	10,5
A512/140 A	NGA5120140HSOCA	357	264	211	176	133	82,3	48,9	34,5	22,3	14,8	12,2
A512/200 A	NGA5120200HSOCA	437	349	282	237	183	115	70,0	49,7	32,3	21,5	17,7

1,70 В/эл – разряд постоянным током в А при 20 °С

A502/10 S	NGA5020010HSOSA	37,0	27,0	20,0	17,0	12,6	7,00	4,20	3,00	1,90	1,25	1,02
A504/3,5 S	NGA50403D5HSOSA	12,1	8,30	6,30	5,20	3,90	2,30	1,40	1,00	0,63	0,41	0,34
A506/1,2 S	NGA50601D2HSOSA	4,32	2,91	2,19	1,77	1,31	0,79	0,52	0,35	0,22	0,13	0,10
A506/3,5 S	NGA50603D5HSOSA	12,1	8,30	6,30	5,20	3,90	2,30	1,40	1,00	0,63	0,41	0,34
A506/6,5 S	NGA50606D5HSOSA	21,0	15,0	12,0	9,50	6,90	3,90	2,30	1,60	1,10	0,76	0,63
A506/10 S	NGA5060010HSOSA	37,0	27,0	20,0	17,0	12,6	7,00	4,20	3,00	1,90	1,25	1,02
A508/3,5 S	NGA50803D5HSOSA	12,1	8,30	6,30	5,20	3,90	2,30	1,40	1,00	0,63	0,41	0,34
A512/1,2 S	NGA51201D2HSOSA	4,32	2,91	2,19	1,77	1,31	0,79	0,52	0,35	0,22	0,13	0,10
A512/2 S	NGA5120002HSOSA	7,40	4,80	3,60	3,00	2,20	1,50	0,88	0,60	0,37	0,24	0,19
A512/3,5 S	NGA51203D5HSOSA	12,1	8,30	6,30	5,20	3,90	2,30	1,40	1,00	0,63	0,41	0,34
A512/6,5 S	NGA51206D5HSOSA	21,0	15,0	12,0	9,50	6,90	3,90	2,30	1,60	1,10	0,76	0,63
A512/10 S	NGA5120010HSOSA	37,0	27,0	20,0	17,0	12,6	7,00	4,20	3,00	1,90	1,25	1,02
A512/16 G5	NGA5120016HSOBA	54,0	39,0	30,0	24,0	17,0	10,5	6,57	4,60	2,92	1,80	1,54
A512/25 G5	NGA5120025HSOBA	61,7	43,3	36,1	29,6	22,4	14,4	8,60	6,20	4,10	2,70	2,20
A512/30 G6	NGA5120030HSOBA	92,0	64,3	50,1	43,3	32,0	20,0	11,6	8,20	5,30	3,40	2,80
A512/40 A	NGA5120040HSOCA*	115	79,0	64,0	52,0	38,0	24,0	13,0	9,50	6,80	4,50	3,70
A512/55 A	NGA5120055HSOCA	151	106	86,8	72,0	53,9	35,5	20,1	14,3	9,30	6,20	5,10
A512/60 A	NGA5120060HSOCA*	178	125	101	82,6	61,6	36,9	22,9	16,2	10,4	6,90	5,60
A512/65 A	NGA5120065HSOCA*	158	121	104	86,2	65,9	40,6	25,1	17,9	11,7	7,60	6,30
A512/85 A	NGA5120085HSOCA	244	182	149	125	93,0	59,0	33,0	23,0	15,1	9,90	8,10
A512/115 A	NGA5120115HSOCA	310	215	183	153	114	67,0	39,0	28,0	19,0	13,0	10,5
A512/120 A	NGA5120120HSOCA	367	249	196	161	119	73,1	42,7	29,9	19,2	12,8	10,5
A512/140 A	NGA5120140HSOCA	397	282	222	183	137	84,1	49,9	35,1	22,6	15,0	12,2
A512/200 A	NGA5120200HSOCA	486	380	300	251	191	117	71,4	50,6	32,8	21,8	17,7

* Характеристики разряда действительны для других выводов / корпусов

Sonnenschein A500

Разряд постоянным током

Тип	Артикул	5 мин.	10 мин.	15 мин.	20 мин.	30 мин.	1 ч.	2 ч.	3 ч.	5 ч.	8 ч.	10 ч.
-----	---------	--------	---------	---------	---------	---------	------	------	------	------	------	-------

1,65 В/эл – разряд постоянным током в А при 20 °С

A502/10 S	NGA5020010HSOSA	39,0	28,0	21,0	17,0	12,7	7,10	4,30	3,00	1,90	1,25	1,02
A504/3,5 S	NGA50403D5HSOSA	12,7	8,50	6,50	5,30	3,90	2,30	1,40	1,01	0,63	0,41	0,34
A506/1,2 S	NGA50601D2HSOSA	4,52	2,96	2,22	1,79	1,32	0,80	0,52	0,36	0,22	0,13	0,10
A506/3,5 S	NGA50603D5HSOSA	12,7	8,50	6,50	5,30	3,90	2,30	1,40	1,01	0,63	0,41	0,34
A506/6,5 S	NGA50606D5HSOSA	23,0	15,0	12,0	9,60	7,00	4,00	2,30	1,60	1,10	0,76	0,63
A506/10 S	NGA5060010HSOSA	39,0	28,0	21,0	17,0	12,7	7,10	4,30	3,00	1,90	1,25	1,02
A508/3,5 S	NGA50803D5HSOSA	12,7	8,50	6,50	5,30	3,90	2,30	1,40	1,01	0,63	0,41	0,34
A512/1,2 S	NGA51201D2HSOSA	4,52	2,96	2,22	1,79	1,32	0,80	0,52	0,36	0,22	0,13	0,10
A512/2 S	NGA5120002HSOSA	7,80	4,90	3,70	3,00	2,20	1,50	0,88	0,60	0,37	0,24	0,19
A512/3,5 S	NGA51203D5HSOSA	12,7	8,50	6,50	5,30	3,90	2,30	1,40	1,01	0,63	0,41	0,34
A512/6,5 S	NGA51206D5HSOSA	23,0	15,0	12,0	9,60	7,00	4,00	2,30	1,60	1,10	0,76	0,63
A512/10 S	NGA5120010HSOSA	39,0	28,0	21,0	17,0	12,7	7,10	4,30	3,00	1,90	1,25	1,02
A512/16 G5	NGA5120016HSOBA	58,0	41,0	30,0	24,0	18,0	10,6	6,61	4,60	2,92	1,80	1,54
A512/25 G5	NGA5120025HSOBA	67,5	45,4	37,1	30,2	22,7	14,4	8,60	6,20	4,10	2,70	2,20
A512/30 G6	NGA5120030HSOBA	98,9	67,0	51,1	44,0	32,4	20,1	11,7	8,20	5,30	3,40	2,80
A512/40 A	NGA5120040HSOCA*	121	82,0	66,0	53,0	39,0	24,0	13,0	9,50	6,80	4,50	3,70
A512/55 A	NGA5120055HSOCA	161	112	88,4	73,6	54,7	35,7	20,2	14,4	9,30	6,20	5,10
A512/60 A	NGA5120060HSOCA*	185	130	102	83,2	61,7	37,1	23,0	16,2	10,4	6,90	5,60
A512/65 A	NGA5120065HSOCA*	178	129	108	88,8	67,0	40,9	25,2	17,9	11,7	7,60	6,30
A512/85 A	NGA5120085HSOCA	259	192	152	128	94,0	59,0	33,0	24,0	15,1	9,90	8,10
A512/115 A	NGA5120115HSOCA	332	222	186	156	116	67,0	39,0	28,0	19,0	13,0	10,5
A512/120 A	NGA5120120HSOCA	387	260	201	165	122	74,0	43,1	30,1	19,2	12,8	10,5
A512/140 A	NGA5120140HSOCA	423	294	229	189	141	85,4	50,3	35,4	22,6	15,0	12,2
A512/200 A	NGA5120200HSOCA	531	395	313	262	198	120	72,1	51,0	32,8	21,8	17,7

1,60 В/эл – разряд постоянным током в А при 20 °С

A502/10 S	NGA5020010HSOSA	42,0	29,0	21,0	17,0	12,8	7,10	4,30	3,00	1,90	1,25	1,02
A504/3,5 S	NGA50403D5HSOSA	13,1	8,70	6,50	5,30	3,90	2,30	1,40	1,01	0,63	0,41	0,34
A506/1,2 S	NGA50601D2HSOSA	4,66	3,00	2,24	1,80	1,33	0,80	0,52	0,36	0,22	0,13	0,10
A506/3,5 S	NGA50603D5HSOSA	13,1	8,70	6,50	5,30	3,90	2,30	1,40	1,01	0,63	0,41	0,34
A506/6,5 S	NGA50606D5HSOSA	24,0	16,0	12,0	9,70	7,00	4,00	2,30	1,60	1,10	0,76	0,63
A506/10 S	NGA5060010HSOSA	42,0	29,0	21,0	17,0	12,8	7,10	4,30	3,00	1,90	1,25	1,02
A508/3,5 S	NGA50803D5HSOSA	13,1	8,70	6,50	5,30	3,90	2,30	1,40	1,01	0,63	0,41	0,34
A512/1,2 S	NGA51201D2HSOSA	4,66	3,00	2,24	1,80	1,33	0,80	0,52	0,36	0,22	0,13	0,10
A512/2 S	NGA5120002HSOSA	8,20	5,00	3,70	3,10	2,20	1,50	0,89	0,60	0,37	0,24	0,19
A512/3,5 S	NGA51203D5HSOSA	13,1	8,70	6,50	5,30	3,90	2,30	1,40	1,01	0,63	0,41	0,34
A512/6,5 S	NGA51206D5HSOSA	24,0	16,0	12,0	9,70	7,00	4,00	2,30	1,60	1,10	0,76	0,63
A512/10 S	NGA5120010HSOSA	42,0	29,0	21,0	17,0	12,8	7,10	4,30	3,00	1,90	1,25	1,02
A512/16 G5	NGA5120016HSOBA	61,0	42,0	31,0	25,0	18,0	10,7	6,62	4,61	2,92	1,80	1,54
A512/25 G5	NGA5120025HSOBA	71,8	46,9	37,7	30,7	22,9	14,5	8,60	6,20	4,10	2,70	2,20
A512/30 G6	NGA5120030HSOBA	105	68,7	51,8	44,4	32,6	20,1	11,7	8,20	5,30	3,40	2,80
A512/40 A	NGA5120040HSOCA*	127	85,0	67,0	54,0	39,0	24,0	13,0	9,50	6,80	4,50	3,70
A512/55 A	NGA5120055HSOCA	169	116	89,3	74,6	55,2	35,8	20,2	14,4	9,30	6,20	5,10
A512/60 A	NGA5120060HSOCA*	191	133	103	83,5	61,8	37,2	23,0	16,2	10,4	6,90	5,60
A512/65 A	NGA5120065HSOCA*	193	135	110	90,3	67,7	41,1	25,2	18,0	11,7	7,60	6,30
A512/85 A	NGA5120085HSOCA	273	199	155	130	95,0	60,0	33,0	24,0	15,1	9,90	8,10
A512/115 A	NGA5120115HSOCA	343	227	187	158	117	68,0	40,0	28,0	19,0	13,0	10,5
A512/120 A	NGA5120120HSOCA	409	267	205	168	124	74,7	43,3	30,2	19,2	12,8	10,5
A512/140 A	NGA5120140HSOCA	452	303	235	193	143	86,3	50,6	35,4	22,6	15,0	12,2
A512/200 A	NGA5120200HSOCA	581	411	323	269	202	121	72,4	51,1	32,8	21,8	17,7

* Характеристики разряда действительны для других выводов / корпусов

Sonnenschein A500

Разряд постоянной мощностью

Тип	Артикул	3 мин.	5 мин.	10 мин.	15 мин.	20 мин.	30 мин.	45 мин.	1 ч.	1,5 ч.
-----	---------	--------	--------	---------	---------	---------	---------	---------	------	--------

1,85 В/эл – разряд постоянной мощностью в Вт/блок при 20 °С

A502/10 S	NGA5020010HSOSA	56,0	50,0	41,0	33,0	27,0	20,0	16,0	13,0	9,00
A504/3,5 S	NGA50403D5HSOSA	41,0	34,0	26,0	21,0	17,0	13,0	11,0	9,00	6,00
A506/1,2 S	NGA50601D2HSOSA	21,4	17,2	12,2	10,3	8,60	6,60	4,90	4,00	3,00
A506/3,5 S	NGA50603D5HSOSA	62,0	51,0	38,0	32,0	26,0	20,0	16,0	13,0	9,00
A506/6,5 S	NGA50606D5HSOSA	120	100	73,0	60,0	51,0	38,0	28,0	23,0	16,0
A506/10 S	NGA5060010HSOSA	167	149	124	98,0	80,0	60,0	49,0	39,0	28,0
A508/3,5 S	NGA50803D5HSOSA	83,0	68,0	51,0	42,0	35,0	27,0	22,0	17,0	12,0
A512/1,2 S	NGA51201D2HSOSA	42,7	34,4	24,3	20,7	17,2	13,2	9,80	8,00	5,90
A512/2 S	NGA5120002HSOSA	74,0	60,0	44,0	36,0	30,0	23,0	17,0	14,0	10,0
A512/3,5 S	NGA51203D5HSOSA	124	102	77,0	63,0	52,0	40,0	33,0	26,0	18,0
A512/6,5 S	NGA51206D5HSOSA	240	200	146	120	102	76,0	56,0	46,0	32,0
A512/10 S	NGA5120010HSOSA	335	298	248	195	160	120	98,0	78,0	56,0
A512/16 G5	NGA5120016HSOBA	485	433	352	295	252	192	150	119	87,0
A512/25 G5	NGA5120025HSOBA	535	463	387	324	278	225	170	140	105
A512/30 G6	NGA5120030HSOBA	857	751	568	479	400	310	251	200	144
A512/40 A	NGA5120040HSOCA*	958	848	703	578	490	395	300	243	178
A512/55 A	NGA5120055HSOCA*	1348	1172	922	844	718	572	457	367	269
A512/60 A	NGA5120060HSOCA*	1618	1414	1096	963	807	625	459	369	271
A512/65 A	NGA5120065HSOCA*	1180	1113	991	861	763	659	500	411	307
A512/85 A	NGA5120085HSOCA	1979	1802	1527	1310	1118	905	690	565	425
A512/115 A	NGA5120115HSOCA	2808	2531	2009	1705	1439	1155	872	702	512
A512/120 A	NGA5120120HSOCA	3350	2862	2300	1895	1583	1200	938	757	583
A512/140 A	NGA5120140HSOCA	3674	3172	2549	2101	1755	1330	1040	839	647
A512/200 A	NGA5120200HSOCA	4690	4102	3449	2843	2375	1800	1408	1135	875

1,80 В/эл – разряд постоянной мощностью в Вт/блок при 20 °С

A502/10 S	NGA5020010HSOSA	56,0	53,0	44,0	35,0	29,0	21,0	17,0	14,0	10,0
A504/3,5 S	NGA50403D5HSOSA	45,0	38,0	28,0	22,0	19,0	14,0	11,0	9,00	6,00
A506/1,2 S	NGA50601D2HSOSA	23,5	19,1	13,3	10,9	9,10	6,90	5,10	4,10	3,00
A506/3,5 S	NGA50603D5HSOSA	68,0	57,0	42,0	33,0	28,0	21,0	17,0	13,0	10,0
A506/6,5 S	NGA50606D5HSOSA	128	112	80,0	63,0	54,0	40,0	30,0	24,0	17,0
A506/10 S	NGA5060010HSOSA	168	159	131	104	86,0	64,0	51,0	41,0	29,0
A508/3,5 S	NGA50803D5HSOSA	91,0	76,0	56,0	44,0	37,0	28,0	23,0	18,0	13,0
A512/1,2 S	NGA51201D2HSOSA	47,0	38,3	26,5	21,7	18,1	13,7	10,2	8,20	6,00
A512/2 S	NGA5120002HSOSA	83,0	68,0	49,0	38,0	32,0	24,0	18,0	15,0	11,0
A512/3,5 S	NGA51203D5HSOSA	136	114	84,0	66,0	56,0	42,0	34,0	27,0	19,0
A512/6,5 S	NGA51206D5HSOSA	256	224	160	126	108	80,0	60,0	48,0	34,0
A512/10 S	NGA5120010HSOSA	336	318	261	209	172	128	101	81,0	59,0
A512/16 G5	NGA5120016HSOBA	584	485	384	309	269	203	156	124	90,0
A512/25 G5	NGA5120025HSOBA	623	555	418	360	303	240	180	146	109
A512/30 G6	NGA5120030HSOBA	1036	850	637	517	433	330	264	210	151
A512/40 A	NGA5120040HSOCA*	1092	1007	758	646	538	415	318	255	186
A512/55 A	NGA5120055HSOCA	1555	1362	1014	888	777	606	478	382	278
A512/60 A	NGA5120060HSOCA*	1955	1634	1181	1041	873	669	489	390	283
A512/65 A	NGA5120065HSOCA*	1459	1316	1109	989	851	693	544	441	327
A512/85 A	NGA5120085HSOCA	2279	2132	1684	1487	1245	970	740	600	447
A512/115 A	NGA5120115HSOCA	3189	2873	2190	1888	1569	1209	926	739	535
A512/120 A	NGA5120120HSOCA	3763	3276	2543	2027	1720	1285	966	794	608
A512/140 A	NGA5120140HSOCA	4127	3631	2819	2246	1906	1424	1070	880	674
A512/200 A	NGA5120200HSOCA	5268	4695	3815	3040	2580	1928	1449	1191	912

* Характеристики разряда действительны для других выводов / корпусов

Sonnenschein A500

Разряд постоянной мощностью

Тип	Артикул	3 мин.	5 мин.	10 мин.	15 мин.	20 мин.	30 мин.	45 мин.	1 ч.	1,5 ч.
-----	---------	--------	--------	---------	---------	---------	---------	---------	------	--------

1,75 В/эл – разряд постоянной мощностью в Вт/блок при 20 °С

A502/10 S	NGA5020010HSOSA	60,0	58,0	45,0	36,0	30,0	22,0	17,0	14,0	10,0
A504/3,5 S	NGA50403D5HSOSA	49,0	41,0	30,0	23,0	20,0	15,0	12,0	9,00	6,00
A506/1,2 S	NGA50601D2HSOSA	25,1	20,7	14,0	11,1	9,30	7,00	5,20	4,20	3,00
A506/3,5 S	NGA50603D5HSOSA	73,0	62,0	45,0	35,0	29,0	22,0	18,0	14,0	10,0
A506/6,5 S	NGA50606D5HSOSA	138	121	86,0	66,0	57,0	42,0	30,0	24,0	17,0
A506/10 S	NGA5060010HSOSA	181	173	135	109	90,0	66,0	51,0	42,0	30,0
A508/3,5 S	NGA50803D5HSOSA	97,0	82,0	60,0	46,0	39,0	29,0	23,0	18,0	13,0
A512/1,2 S	NGA51201D2HSOSA	50,1	41,4	28,0	22,2	18,6	14,0	10,3	8,30	6,10
A512/2 S	NGA5120002HSOSA	91,0	75,0	52,0	40,0	33,0	25,0	18,0	15,0	11,0
A512/3,5 S	NGA51203D5HSOSA	146	123	89,0	69,0	59,0	44,0	35,0	27,0	19,0
A512/6,5 S	NGA51206D5HSOSA	276	242	172	132	114	84,0	60,0	48,0	34,0
A512/10 S	NGA5120010HSOSA	361	346	270	219	179	132	103	83,0	60,0
A512/16 G5	NGA5120016HSOBA	636	534	407	322	280	209	159	126	91,0
A512/25 G5	NGA5120025HSOBA	689	616	454	385	320	248	185	150	111
A512/30 G6	NGA5120030HSOBA	1118	951	690	538	453	341	271	214	153
A512/40 A	NGA5120040HSOCA*	1226	1074	822	691	569	432	326	261	189
A512/55 A	NGA5120055HSOCA	1799	1496	1102	917	813	626	489	388	281
A512/60 A	NGA5120060HSOCA*	2267	1837	1274	1071	915	693	505	400	288
A512/65 A	NGA5120065HSOCA*	1757	1591	1223	1083	914	721	567	457	336
A512/85 A	NGA5120085HSOCA	2561	2292	1847	1557	1329	1018	768	621	460
A512/115 A	NGA5120115HSOCA	3642	3101	2374	1986	1653	1255	956	759	547
A512/120 A	NGA5120120HSOCA	4237	3552	2627	2134	1800	1334	989	815	622
A512/140 A	NGA5120140HSOCA	4647	3937	2912	2365	1995	1479	1096	904	689
A512/200 A	NGA5120200HSOCA	5932	5092	3941	3201	2700	2002	1484	1223	933

1,70 В/эл – разряд постоянной мощностью в Вт/блок при 20 °С

A502/10 S	NGA5020010HSOSA	64,0	60,0	46,0	38,0	31,0	22,0	17,0	14,0	10,0
A504/3,5 S	NGA50403D5HSOSA	53,0	44,0	31,0	24,0	20,0	15,0	12,0	9,00	7,00
A506/1,2 S	NGA50601D2HSOSA	26,8	21,9	14,4	11,2	9,40	7,10	5,20	4,20	3,10
A506/3,5 S	NGA50603D5HSOSA	80,0	66,0	46,0	36,0	30,0	22,0	18,0	14,0	10,0
A506/6,5 S	NGA50606D5HSOSA	150	126	88,0	68,0	58,0	42,0	31,0	24,0	17,0
A506/10 S	NGA5060010HSOSA	193	180	139	113	92,0	67,0	52,0	42,0	30,0
A508/3,5 S	NGA50803D5HSOSA	106	88,0	61,0	48,0	40,0	30,0	24,0	19,0	13,0
A512/1,2 S	NGA51201D2HSOSA	53,7	43,7	28,8	22,4	18,8	14,1	10,4	8,40	6,10
A512/2 S	NGA5120002HSOSA	99,0	80,0	53,0	41,0	34,0	25,0	19,0	15,0	11,0
A512/3,5 S	NGA51203D5HSOSA	159	131	92,0	72,0	60,0	45,0	35,0	28,0	20,0
A512/6,5 S	NGA51206D5HSOSA	300	252	176	136	116	84,0	62,0	48,0	34,0
A512/10 S	NGA5120010HSOSA	385	360	278	226	185	135	103	84,0	60,0
A512/16 G5	NGA5120016HSOBA	688	573	418	331	285	212	161	127	91,0
A512/25 G5	NGA5120025HSOBA	776	652	482	395	330	253	187	151	112
A512/30 G6	NGA5120030HSOBA	1214	1037	726	558	465	347	274	216	155
A512/40 A	NGA5120040HSOCA*	1391	1157	870	719	587	441	331	264	191
A512/55 A	NGA5120055HSOCA	1912	1624	1163	935	834	636	493	392	283
A512/60 A	NGA5120060HSOCA*	2406	2022	1348	1088	940	707	514	405	290
A512/65 A	NGA5120065HSOCA*	1959	1739	1322	1142	954	739	577	464	340
A512/85 A	NGA5120085HSOCA	2900	2486	1993	1607	1381	1045	786	634	469
A512/115 A	NGA5120115HSOCA	4106	3361	2511	2030	1703	1281	971	770	553
A512/120 A	NGA5120120HSOCA	4536	3800	2690	2201	1849	1365	1008	830	632
A512/140 A	NGA5120140HSOCA	4974	4211	2981	2440	2050	1513	1117	920	700
A512/200 A	NGA5120200HSOCA	6350	5446	4034	3302	2774	2048	1512	1245	948

* Характеристики разряда действительны для других выводов / корпусов

Sonnenschein A500

Разряд постоянной мощностью

Тип	Артикул	3 мин.	5 мин.	10 мин.	15 мин.	20 мин.	30 мин.	45 мин.	1 ч.	1,5 ч.
-----	---------	--------	--------	---------	---------	---------	---------	---------	------	--------

1,65 В/эл – разряд постоянной мощностью в Вт/блок при 20 °С

A502/10 S	NGA5020010HSOSA	68,0	62,0	47,0	38,0	31,0	23,0	17,0	14,0	10,0
A504/3,5 S	NGA50403D5HSOSA	57,0	46,0	31,0	24,0	20,0	15,0	12,0	9,00	7,00
A506/1,2 S	NGA50601D2HSOSA	28,2	22,6	14,7	11,2	9,50	7,10	5,20	4,20	3,10
A506/3,5 S	NGA50603D5HSOSA	85,0	68,0	47,0	36,0	30,0	23,0	18,0	14,0	10,0
A506/6,5 S	NGA50606D5HSOSA	160	129	90,0	69,0	59,0	43,0	31,0	25,0	18,0
A506/10 S	NGA5060010HSOSA	205	186	142	114	93,0	68,0	52,0	42,0	30,0
A508/3,5 S	NGA50803D5HSOSA	113	91,0	62,0	49,0	41,0	30,0	24,0	19,0	13,0
A512/1,2 S	NGA51201D2HSOSA	56,4	45,3	29,4	22,5	18,9	14,2	10,5	8,40	6,10
A512/2 S	NGA5120002HSOSA	103	82,0	54,0	41,0	34,0	25,0	19,0	15,0	11,0
A512/3,5 S	NGA51203D5HSOSA	170	137	93,0	73,0	61,0	45,0	35,0	28,0	20,0
A512/6,5 S	NGA51206D5HSOSA	320	258	180	138	118	86,0	62,0	50,0	36,0
A512/10 S	NGA5120010HSOSA	410	371	283	229	187	136	104	84,0	61,0
A512/16 G5	NGA5120016HSOBA	741	601	423	335	288	213	161	128	92,0
A512/25 G5	NGA5120025HSOBA	854	693	501	400	335	255	188	152	112
A512/30 G6	NGA5120030HSOBA	1310	1095	746	569	471	351	276	217	155
A512/40 A	NGA5120040HSOCA*	1514	1235	902	729	597	446	333	265	192
A512/55 A	NGA5120055HSOCA	2005	1726	1204	945	845	642	496	394	284
A512/60 A	NGA5120060HSOCA*	2548	2176	1404	1098	954	715	519	409	292
A512/65 A	NGA5120065HSOCA*	2139	1853	1395	1171	976	749	582	466	341
A512/85 A	NGA5120085HSOCA	3115	2719	2109	1663	1410	1060	797	642	474
A512/115 A	NGA5120115HSOCA	4304	3582	2603	2057	1732	1296	980	776	557
A512/120 A	NGA5120120HSOCA	4847	4002	2761	2246	1883	1387	1022	843	640
A512/140 A	NGA5120140HSOCA	5316	4435	3060	2489	2087	1538	1133	934	709
A512/200 A	NGA5120200HSOCA	6786	5736	4142	3369	2825	2081	1533	1264	959

1,60 В/эл – разряд постоянной мощностью в Вт/блок при 20 °С

A502/10 S	NGA5020010HSOSA	73,0	63,0	48,0	38,0	31,0	23,0	17,0	14,0	10,0
A504/3,5 S	NGA50403D5HSOSA	59,0	46,0	32,0	25,0	20,0	15,0	12,0	9,00	7,00
A506/1,2 S	NGA50601D2HSOSA	29,2	23,1	14,8	11,3	9,50	7,10	5,20	4,20	3,10
A506/3,5 S	NGA50603D5HSOSA	89,0	69,0	47,0	37,0	31,0	23,0	18,0	14,0	10,0
A506/6,5 S	NGA50606D5HSOSA	168	132	92,0	70,0	59,0	43,0	31,0	25,0	18,0
A506/10 S	NGA5060010HSOSA	218	190	144	115	94,0	68,0	52,0	42,0	30,0
A508/3,5 S	NGA50803D5HSOSA	119	93,0	63,0	49,0	41,0	30,0	24,0	19,0	13,0
A512/1,2 S	NGA51201D2HSOSA	58,4	46,2	29,7	22,5	19,0	14,2	10,5	8,40	6,20
A512/2 S	NGA5120002HSOSA	106	84,0	55,0	42,0	34,0	25,0	19,0	15,0	11,0
A512/3,5 S	NGA51203D5HSOSA	178	139	95,0	74,0	61,0	45,0	36,0	28,0	20,0
A512/6,5 S	NGA51206D5HSOSA	336	264	184	140	118	86,0	62,0	50,0	36,0
A512/10 S	NGA5120010HSOSA	437	381	287	231	188	136	104	85,0	61,0
A512/16 G5	NGA5120016HSOBA	783	621	426	338	289	214	162	128	92,0
A512/25 G5	NGA5120025HSOBA	908	725	514	403	339	256	189	153	113
A512/30 G6	NGA5120030HSOBA	1393	1121	755	576	474	352	276	218	156
A512/40 A	NGA5120040HSOCA*	1577	1299	923	735	603	449	334	266	192
A512/55 A	NGA5120055HSOCA	2107	1800	1231	957	851	645	498	395	285
A512/60 A	NGA5120060HSOCA*	2680	2279	1439	1104	963	719	522	410	293
A512/65 A	NGA5120065HSOCA*	2315	1976	1443	1183	987	754	584	468	342
A512/85 A	NGA5120085HSOCA	3264	2923	2190	1700	1427	1069	804	648	477
A512/115 A	NGA5120115HSOCA	4467	3755	2665	2073	1750	1306	985	780	560
A512/120 A	NGA5120120HSOCA	5135	4156	2812	2276	1906	1403	1032	852	646
A512/140 A	NGA5120140HSOCA	5631	4606	3117	2522	2113	1555	1144	945	716
A512/200 A	NGA5120200HSOCA	7189	5957	4218	3413	2860	2104	1548	1279	969

* Характеристики разряда действительны для других выводов / корпусов